

CULITEK HD-Series Reach Ins

Models: R1SS, R2SS, R3SS, F1SS, F2SS, F3SS

EQUIPMENT THAT DOMINATES
For Culinary Professionals



R1SS/F1SS



R2SS/F2SS

HD-Series Refrigerators and Freezers

The CULITEK HD-Series Refrigerators and Freezers have 304 corrosion-resistant stainless steel interior and 430 stainless steel exterior. Available in 1, 2, and 3 door models, each unit includes standard features, such as LED interior lighting, digital temperature controller, pre-installed casters, self-closing doors, and environmentally friendly, R-290 refrigerant. Advanced design, R290 Cubigel Compressors®, minimizes operating costs and provides higher cooling capacity and increased energy savings. Backed by a 2 year warranty on parts and a 5 year warranty on the compressor, all models are EnergyStar® rated [R1SS, R2SS, R3SS, F1SS, F2SS, F3SS], NSF-7 certified, and ETL and ETL Sanitation listed.

Cooling System

- Environmentally-friendly R290 hydrocarbon refrigerant is free of ozone-depleting properties
- Advanced design, R290 Cubigel Compressors® series, minimizes operating costs and provides higher cooling capacity and energy savings
- Top down airflow helps to maintain a temperature range of 33°F to 40°F (refrigerators) and -8°F to 0°F (freezers)

Cabinet Construction

- 304 corrosion resistant stainless steel interior and 430 stainless steel exterior
- Coated coils
- Superior fit and finishing, including smooth edges

Electrical Control

- Carel digital temperature control

Optional — Extra Shelves, includes 4 shelf clips per shelf

Door(s)

- Stainless steel exterior and interior
- Self-closing door, with stay open feature beyond 90°
- Magnetic door gasket(s) standard for positive door seal
- Recessed handles are built into the door for easy opening and closing
- Locking door keep items inside secure after hours

Shelving

- Three pre-installed shelves per section
- Shelves have preinstalled stainless steel pilasters with clips and epoxy coated wire shelves
- Shelves can hold up to 90 lbs



Model Features

- LED interior light(s)
- Pre-installed 4" casters shipped in a break-away skid for easy unpacking and set up

STANDARD FEATURES

- 304 corrosion resistant stainless steel interior and 430 stainless steel exterior
- Carel digital temperature control ranges 33°F to 40°F in refrigerators and -8°F to 0°F in freezers
- Advanced design R290 Cubigel Compressor® minimizes operating costs and provides higher cooling capacity and increased energy savings
- Pre-installed shelves feature stainless steel pilasters with clips and epoxy coated wire shelves
- Shelves can hold up to 90 lbs
- Self-closing door, with stay open feature beyond 90°
- Eco-friendly R290 hydrocarbon refrigerant
- Packed in a breakaway skid for easy unpacking and set up



[R1SS, R2SS, R3SS, F1SS, F2SS, F3SS]



Attention CA Residents
PROP 65 WARNING
This product can expose you to chemicals, including lead, which are known to the State of California to cause cancer, birth defects, or other reproductive harm. For more information, go to www.P65warnings.ca.gov

MADE IN CHINA

Models: R1SS, F1SS

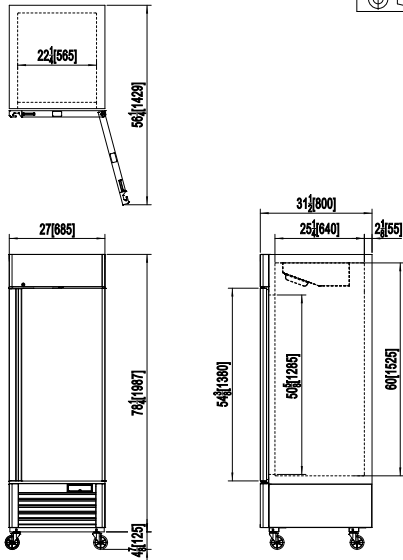

Models: R2SS, F2SS

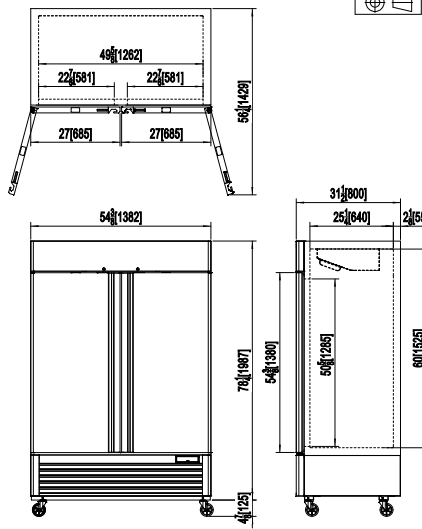

Models: R3SS, F3SS

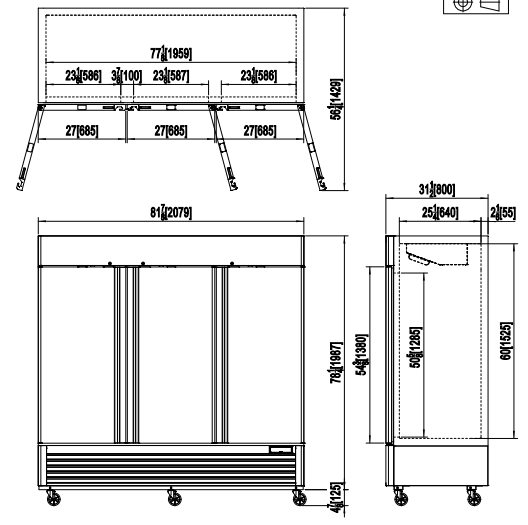

REFRIGERATORS

Model Number	R1SS	R2SS	R3SS
Doors	1	2	3
Shelves	3	6	9
Net Volume (Cu. Ft.)	19.1	43.8	68
Overall Dimensions (in)	27"Wx31 ⁷ / ₁₀ "Dx83 ¹ / ₁₀ "H	54 ² / ₅ "Wx31 ⁷ / ₁₀ "Dx83 ¹ / ₁₀ "H	81 ⁹ / ₁₀ " x 31 ⁷ / ₁₀ "D x 83 ¹ / ₁₀ "H
Interior Dimensions (in)	22 ¹ / ₄ "Wx50 ⁵ / ₈ "H	22 ⁷ / ₈ "W /section, 49 ⁵ / ₈ "W Overall	23 ¹ / ₈ "W /section, 77 ¹ / ₈ "W Overall
Horsepower	1/7	1/5	1/5
Refrigerant	R290	R290	R290
Voltage/Hertz/Phase	115/60/1	115/60/1	115/60/1
Amps	2.1	3.2	4.2
Net Weight (lbs)	249	397	538
Gross Weight (lbs)	282	452	615

FREEZERS

Model Number	F1SS	F2SS	F3SS*
Doors	1	2	3
Shelves	3	6	9
Net Volume (Cu. Ft.)	19.1	44.8	68
Overall Dimensions (in)	27"Wx31 ⁷ / ₁₀ "Dx83 ¹ / ₁₀ "H	54 ² / ₅ "Wx31 ⁷ / ₁₀ "Dx83 ¹ / ₁₀ "H	81 ⁹ / ₁₀ "Wx31 ⁷ / ₁₀ "Dx83 ¹ / ₁₀ "H
Interior Dimensions (in)	22 ¹ / ₄ "Wx50 ⁵ / ₈ "H	22 ⁷ / ₈ "W /section, 9 ⁵ / ₈ "W Overall	23 ¹ / ₈ "W /section, 77 ¹ / ₈ "W Overall
Horsepower	1/2	3/4	1-1/4
Refrigerant	R290	R290	R290
Voltage/Hertz/Phase	115/60/1	115/60/1	115/60/1
Amps	6.3	8.6	5.5
Net Weight (lbs)	265	410	551
Gross Weight (lbs)	298	465	628

* 3 door bottom mount freezer uses a NEMA-L14-20R